

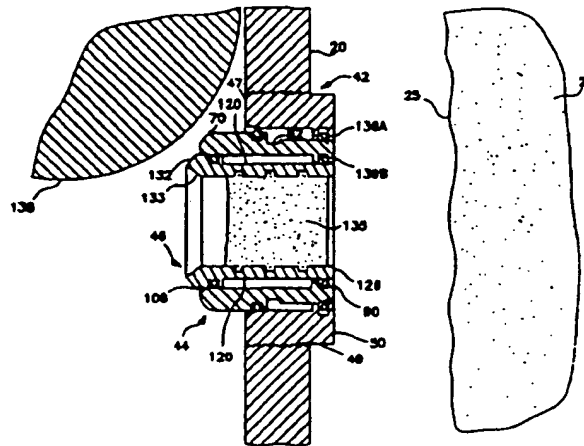

INTERNATIONAL APPLICATION PUBLISHED UNDER THE PATENT COOPERATION TREATY (PCT)

(51) International Patent Classification ⁶ : E21B 43/11, 43/08	A1	(11) International Publication Number: WO 96/26350
		(43) International Publication Date: 29 August 1996 (29.08.96)
<p>(21) International Application Number: PCT/US96/02050</p> <p>(22) International Filing Date: 14 February 1996 (14.02.96)</p> <p>(30) Priority Data: 08/388,663 14 February 1995 (14.02.95) US</p> <p>(71) Applicant: BAKER HUGHES INCORPORATED [US/US]; Suite 1200, 3900 Essex Lane, Houston, TX 77027 (US).</p> <p>(72) Inventors: JOHNSON, Michael, H.; 6505 Allentown Drive, Spring, TX 77389 (US). MCMULLIN, Dale, R.; 505 Cypress Station, No. 1106, Houston, TX 77090 (US).</p> <p>(74) Agents: ROWOLD, Carl, A. et al.; Baker Hughes Incorporated, Suite 1200, 3900 Essex Lane, Houston, TX 77027 (US).</p>	<p>(81) Designated States: AM, AT, AU, BB, BG, BR, BY, CA, CH, CN, CZ, DE, DK, EE, ES, FI, GB, GE, HU, JP, KE, KG, KP, KR, KZ, LK, LR, LT, LU, LV, MD, MG, MN, MW, MX, NO, NZ, PL, PT, RO, RU, SD, SE, SI, SK, TJ, TT, UA, UZ, VN, ARIPO patent (KE, LS, MW, SD, SZ, UG), European patent (AT, BE, CH, DE, DK, ES, FR, GB, GR, IE, IT, LU, MC, NL, PT, SE), OAPI patent (BF, BJ, CF, CG, CI, CM, GA, GN, ML, MR, NE, SN, TD, TG).</p> <p>Published With international search report. Before the expiration of the time limit for amending the claims and to be republished in the event of the receipt of amendments.</p>	

(54) Title: CASING WITH A LATERALLY EXTENDABLE TUBULAR MEMBER AND METHOD FOR SAND CONTROL IN WELLS



(57) Abstract

A method and apparatus of completing a well is disclosed. Generally, the method comprises the steps of positioning a casing (20) into a well bore. The casing will have a segment with an aperture for placement of the completion means (26, 40). The completion means may contain permeable means (135) for allowing the flow of the reservoir's fluid and gas; first (44) and second (46) extendable means, encasing the permeable means, for extending the permeable means so that the reservoir's fluid and gas can flow therethrough; and activating means for activating the extendable means from the retracted position to the expanded position. The method further comprises the steps of correlating the position of the completion means with the target reservoir so that the completion means is adjacent the target reservoir; and extending the completion means to the reservoir.

FOR THE PURPOSES OF INFORMATION ONLY

Codes used to identify States party to the PCT on the front pages of pamphlets publishing international applications under the PCT.

AM	Armenia	GB	United Kingdom	MW	Malawi
AT	Austria	GE	Georgia	MX	Mexico
AU	Australia	GN	Guinea	NE	Niger
BB	Barbados	GR	Greece	NL	Netherlands
BE	Belgium	HU	Hungary	NO	Norway
BF	Burkina Faso	IE	Ireland	NZ	New Zealand
BG	Bulgaria	IT	Italy	PL	Poland
BJ	Benin	JP	Japan	PT	Portugal
BR	Brazil	KE	Kenya	RO	Romania
BY	Belarus	KG	Kyrgyzstan	RU	Russian Federation
CA	Canada	KP	Democratic People's Republic of Korea	SD	Sudan
CF	Central African Republic	KR	Republic of Korea	SE	Sweden
CG	Congo	KZ	Kazakhstan	SG	Singapore
CH	Switzerland	LI	Liechtenstein	SI	Slovenia
CI	Côte d'Ivoire	LK	Sri Lanka	SK	Slovakia
CM	Cameroon	LR	Liberia	SN	Senegal
CN	China	LT	Lithuania	SZ	Swaziland
CS	Czechoslovakia	LU	Luxembourg	TD	Chad
CZ	Czech Republic	LV	Latvia	TG	Togo
DE	Germany	MC	Monaco	TJ	Tajikistan
DK	Denmark	MD	Republic of Moldova	TT	Trinidad and Tobago
EE	Estonia	MG	Madagascar	UA	Ukraine
ES	Spain	ML	Mali	UG	Uganda
FI	Finland	MN	Mongolia	US	United States of America
FR	France	MR	Mauritania	UZ	Uzbekistan
GA	Gabon			VN	Viet Nam

CASING WITH A Laterally extendable tubular member and method for sand control in wells.

BACKGROUND OF THE INVENTION

This invention relates to a method of completing a well. More particularly, but not
5 by way of limitation, this invention relates to a method and apparatus for placing a sand control apparatus within a wellbore intersecting a hydrocarbon reservoir.

The search for oil and gas reserves has taken the industry to remote sites including inland and offshore locations. Historically, the cost for exploring and
10 developing hydrocarbons has been very high, and as the search for hydrocarbons continues in these remote areas, cost are escalated because of the amount of equipment and personnel required in these areas.

Exploratory wells will often encounter hydrocarbons zones; however, only a
15 fraction of the zones ultimately encountered can be determined to contain reserves sufficient to justify field development. Once sufficient reserves have been found, the well must be completed so that the hydrocarbons can be produced. Operators, therefore, desire maximum recovery from productive zones, and in order to produce this maximize production, a proper completion is required.

20

Many hydrocarbon reservoirs are by their nature unconsolidated rock and/or sandstone. Thus, these formations may produce sand particles and other debris which can cause well bore and surface facility problems, as well as affecting the productivity of the well. Therefore, means for preventing sand production have been developed
25 throughout th years.

One common method is to concentrically place a screen in the casing annulus adjacent the producing reservoir. The annulus is formed with a production casing intersecting the reservoir, with the casing being perforated so that the reservoir is in communication with the casing annulus. The sand control screen for preventing formation sand from being produced may be included. The screen may be a slotted liner, or alternatively, a wire wrapped screen placed about a segment of perforated pipe. Further, a gravel pack slurry may be pumped down hole into this annulus area as is well known by those of ordinary skill in the art.

Current techniques include the time consuming procedure of positioning in the well bore adjacent the casing a perforating device, and firing or exploding the device. Withdrawal or release of the perforating device is then necessary. Next, a gravel packing tool must be located in the well bore. Thereafter, a gravel slurry may be placed in the annulus.

An illustrative list of the disadvantages from the above procedure follows. First, the perforating through the casing and into the formation may cause damage to the formation, and afterwards, the perforated tunnel will have to be packed with gravel. Second, the formation is exposed to damaging drilling and/or completion fluids. Third, the gravel pack assembly is situated within the well bore thereby serving as a restriction that in turn causes unnecessary pressure drops. Also, if remedial action needs to be taken, removing the screen or liner may prove to be costly or prohibitive causing hydrocarbons in the reservoir to be lost to future production.

Therefore, there is a need for a method and apparatus for completing a well that minimizes time spent in completing the well. Further, there is a need for a method and apparatus that minimizes formation damage and maximizes the productivity of the well. Also, there is a need for the testing of exploratory wells that is faster and economical.

5

SUMMARY OF THE INVENTION

A method of completing a well is disclosed. The method comprises the steps of positioning a casing string into a well bore, with the casing having a segment with an aperture for placement of completion means for completing to a target reservoir. The completion means may include permeable means for allowing the flow of the target reservoir's fluid and gas; hydraulic extendable means, encasing said permeable means, for extending said permeable means into the target reservoir; mechanical extendable means, fitted within said aperture and having disposed therein said hydraulic extendable means, for extending said hydraulic means from said casing string from a first position to a second position by mechanical means; mechanical and/or hydraulic activating means for activating said mechanical and/or hydraulic extendable means from the retracted position to the expanded position.

The method may further include the steps of correlating the position of the completion means with the target reservoir so that the completion means is adjacent the target reservoir. Then lowering the mechanical activating means, and extending the mechanical extendable means from the casing housing. Next, pressure is applied to the casing string which in turn extends the hydraulic extending means to the target reservoir.

The permeable means may contain a soluble compound means for preventing infiltration into the permeable means the drilling fluids and cuttings of the wellbore, and the method further comprises the steps of treating the permeable means so as to remove said soluble compound; and, thereafter placing the well on production.

5

The mechanical extending means comprises a housing disposed within an opening in the casing; a first sleeve being disposed within said housing and being radially extendable, the first sleeve having an outer portion and inner portion with the inner portion containing thereon a detent means, operatively associated with the housing, for preventing backward motion of the first sleeve. The hydraulic extending means comprises a hydraulic sleeve being disposed within said first sleeve and being radially extendable, with the hydraulic sleeve having an inner portion and an outer portion containing a plurality of ratchet members that cooperate with the detent means of the first sleeve. The activating means includes a wiper casing plug.

10

Utilizing this embodiment, the step of extending said mechanical extending means includes engaging the wiper casing plug with the first end of said first sleeve. The step of extending said hydraulic extending means includes pressuring on the hydraulic sleeve so that the ratchet pawl members engage with the detent means of the mechanical extending means.

15

A device for producing a fluid and gas from a subterranean reservoir is also disclosed. The device comprises a conduit intersecting the reservoir, the conduit having an inner and outer diameter, the conduit having disposed therein a passageway, a

consolidated medium (which may be a plurality of metal beads) disposed within the passageway, with the medium sized to prevent passage of the reservoir sand; telescoping arm means, encircling said medium, for advancing the sand control means into contact with the reservoir; mechanical and/or hydraulic activating means, disposed on the telescoping arm means, for mechanically activating said telescoping arm means; hydraulic activating means, disposed on the telescoping arm means, for mechanically activating the telescoping arm means. The bead medium may contain disposed thereon a soluble compound.

10 A method of testing an exploratory well to a target reservoir is also disclosed. The method includes the steps of positioning in the exploratory well a casing string, the casing string containing a segment including completion means for completing the well to the target reservoir. Next, the position of the completion means is correlated so that the completion means is adjacent the target reservoir, activating the completion means
15 so that said permeable means contacts the target reservoir, and, testing the hydrocarbon zone by flowing the target reservoir.

In one embodiment, the exploratory well will contain a lower, an intermediate, and an upper target reservoir. In this case, the step of positioning in the casing string
20 includes placing the completion means in the casing string so that the completion means corresponds to depths of the lower, intermediate and upper target reservoir. The step of testing the hydrocarbon zones includes lowering a test string having thereon a retrievable isolation packer means for isolating the well bore; setting the isolation packer means at a position above the lower target reservoir but below the intermediate target

reservoir, flowing the well from the lower target reservoir.

The method may further comprise the steps of shutting-in the well; placing a bridge plug in the well at a point above the lower target reservoir; repositioning the isolation packer means to a point above the intermediate reservoir, then, setting the
5 isolation packer means, and flowing the well from the intermediate reservoir.

Then, the operator would shut-in the well and place a bridge plug in the well at a point above the intermediate tested reservoir; repositioning the isolation packer means
10 to a point above the highest reservoir; setting said isolation packer means;
flowing the well from the upper hydrocarbon reservoir.

Also disclosed is a method of manufacturing a sand control screen comprising the steps of providing a cylindrical container having a first end and a second end. Then,
15 a soluble disc member or cap is press-fitted at the first end of the cylindrical container. Next, a plurality of beads (which may be metal) is placed within a container member; the container is positioned with the beads within a heating chamber and a bonding powder is added to the container. The method then includes evacuating the heating chamber of
air, filling the heating chamber with a gas such as hydrogen gas; and, heating the
20 chamber in order to consolidate the plurality of beads. In one embodiment, the beads contain a metal bead and a brazing powder consisting of phosphorous, chromium, nickel, and iron. Other types of bonding materials and beads may be used. In these instances, the method of bonding the beads will depend on the nature of the bonding material, and the nature of the beads.

A feature of the present invention includes use of a permeable core that may consist of brazed metal, sintered metal, rigid open cell foam, resin coated sand or a porous hydrophilic membrane. Another feature of the invention includes use of a soluble compound surrounding the porous element which can be dissolved and/or
5 removed at the option of the operator so that the porous element may be selectively opened. Still yet another feature is that for multiple formation wells, the productive intervals may be selectively opened during remedial well work by dissolving the soluble compound.

10 Another feature of the invention includes the ability of extending the sand control means from the retracted position to the expanded position as desired by the operator. Still yet another feature includes having the ability to have mechanical, hydraulic or other activating means used to extend the sand control means.

15 Yet another feature includes that after having the casing and cores in contact with the formation face, the inner diameter of the casing will be maximized. Another feature is that of having the sand control means only on the outer diameter of the casing, rather than the inside and outside of the casing as is the case with prior art gravel packs.

20 Still another feature includes using a membrane for the completion means that will allow the passage of a hydrocarbon fluid or gas, but not in-situ water when a hydrophilic membrane is used. Another feature is the use of the completion means that can be selectively placed in the casing string at remote sites, including if necessary at

the rig site. Another feature is shaping the face of the completion insert so as to embed its lf into th formation surface as it is being extending.

Another feature includes use of an atmospheric chamber to extend the completion means, or alternatively, the use of mechanical means. Another feature
5 includes having a two step procedure for extending the core including utilizing mechanical means and then hydraulic means, or alternatively, a two step hydraulic activation.

10 An advantage of the present invention includes eliminating the placement of a gravel pack screen/liner on the inner diameter of the casing. This in turn saves time and allows for a virtually unobstructed inner diameter well bore that decreases pressure drop through the zone. Yet another advantage includes eliminating the need for lowering into the well bore a perforating gun, which in turn saves time.

15 Another advantage is that by minimizing the time completing the well, the less time there is for the drilling and completion fluid damaging the formation. Another advantage includes saving substantial money by using less completion equipment. Another advantage includes being able to test exploratory wells by custom designing
20 the casing string after the open hole logs have been run indicating the position of the hydrocarbon zones, and thereafter test the zones one at a time. Another advantage includes use of a metal core which is highly porous, permeable, and that has very high compressive strength values.

BRIEF DESCRIPTION OF THE DRAWINGS

FIGURE 1 is an illustration of a drilling rig on a drilling platform having a bore hole section that intersects multiple subterranean reservoirs.

5 FIGURE 2 is an isometric cross-sectional view of the completion means that is positioned within a conduit in a well bore.

FIGURE 3 is a cross-sectional view of the mechanical activation means and the completion means before extending.

10

FIGURE 4 is a cross-sectional view of the completion means as seen in Fig. 3 after being expanded into contact with the formation.

FIGURE 5 is a cross-sectional view of the expanded completion means with a
15 diverter means being positioned therein.

FIGURE 6 is a cross-sectional view of a well test string schematic shown testing a lower formation.

20 FIGURE 7 is a cross-sectional view of the well test string schematic of Fig. 6 shown testing the intermediate formation.

FIGURE 8 is a cross-sectional view of the well test string schematic of Fig. 7 shown testing the higher formation.

DESCRIPTION OF THE PREFERRED EMBODIMENTS

Referring to Fig. 1, a semi-submersible drilling vessel 2 that has contained
5 thereon a drilling rig 4. A sub-sea Blow-Out Preventor stack (not shown) may be
positioned on the ocean floor 10, with a riser 12 linking the sub-sea stack 8 with the
vessel 2. The well casing strings include the conductor, surface, and intermediate 14,
16, and 18, respectfully.

10 As is well understood by those of ordinary skill in the art, the casing strings will
intersect various subterranean reservoirs 22, some of which may contain hydrocarbons.

As is shown in Fig. 1, the target reservoir 24 has the production casing string 20
positioned adjacent thereto, with the production casing string 20 being positioned within
the riser 12 and casing string 18. The string 20 has inserted therein a plurality of
15 completion means 26 for controlling the production of a reservoir sand (also referred to
as an extendable perforation means for reasons that will become evident hereinafter),
with the completion means 26 being positioned within openings contained in the walls of
the string 20. It should be noted that throughout the description of the preferred
embodiments, like numbers used in the various figures refer to like components.

20 Referring to Fig. 2, an isometric view of the preferred embodiment is shown. The
completion means, seen generally at 40, comprises a housing member 42, a first sleeve
44 and a second sleeve 46. The housing member 42 has an outer diameter surface 48
that has contained thereon an external thread 49 for mating with a matching thread on
the casing string 20 that will effectively seal the housing member within an opening

contained in the wall of casing 20. The outer diameter surface 48 will extend to a radially flat surface 50. Extending radially inward will be first inner bore surface 52 that extends to radial surface 53 that in turn leads to the short inner surface 54 that will stretch to the radial flat surface 56 which terminates at the second inner surface 58. The
5 second inner surface 58 leads to the radial shoulder 60 which in turn leads to the third inner diameter surface 62 and concludes at chamfered surface 64, with the chamfered surface 64 terminating at the radial shoulder 66. The surfaces 52, 53, 54, and 56 form a cavity for the placement of the detent means for preventing backward movement of the first sleeve 44 which in the preferred embodiment will be a snap ring (not shown) which
10 will cooperate with the first sleeve 44, as will be described hereinafter.

The first sleeve 44 generally comprises an outer diameter surface 68 that has a first end 70 that is a curved surface that will cooperate with a wiper plug tool 138. The outer diameter surface 68 will stretch to the shoulder 72 that in turn leads to the outer
15 surface 74 that terminates at the shoulder 76. The surfaces 72, 74 and 76 allow for placement of sealing means such as an "O-Ring". The shoulder 76 extends to the outer surface 78 and terminates at radially flat surface 80 that stretches to the outer surface 82 that terminates at shoulder 84. The shoulder 84 will then extend to outer surface 86 that will have contained therein notch 88, with the surface 86 terminating at the radially
20 flat end 90.

The inner diameter of the sleeve 44 contains a first bore surface 92 that extends a short distance to the shoulder 94 that in turn leads to the inner surface 96 that stretches to shoulder 98. The shoulder 98 terminates at the outer surface 100 that in

turn stretches to the radial surface 102 which then leads to the inner bore surface 104 that ultimately terminates at the chamfered surface 106. The sleeve 44 will also contain the detent means 139B (which in the preferred embodiment is a snap ring member) for preventing the backward movement of the second sleeve 46.

5

The second sleeve 46, which also serves as the container for the bead core (which may be a metal core), will now be described. The second sleeve generally comprises an outer diameter surface 110 that leads to a radial shoulder 112 that in turn stretches to another outer diameter surface 114 that terminates at the lip 116 so that the shoulder 112, surface 114 and lip 116 define a groove for placement of a sealing member. The surfaces 112 and 114 allow for placement of sealing means such as an "O-Ring". The lip 116 leads to the outer diameter surface 118 that will contain thereon a plurality of ratchet grooves 120, with each individual ratchet groove 120 arranged so that a radial shoulder 122 leads to an inclined surface 124.

15

The ratchet grooves 120 will conclude at the radial surface 126, and extending inward will be the inner bore surface 128 that will have contained thereon a plurality of grooves 130 formed thereon. The inner bore surface 128 will extend to chamfered surfaces 132 and 133. A soluble disc 134 is also included with the second sleeve 46 and fitted such that a container is formed for the placement of the porous core, but a cap member (not shown) could also be used when pressure is applied to the internal diameter of the casing 20. The cap would be designed to pop off at a given pressure. It should be noted that the chamfered surface 132 is contoured such that a spherical ball of the proper diameter may be set in the seat profile 132 so that the ball will seat and

20

seal when the pressure is greater on the inner diameter than the outer diameter of the casing 20 as seen in Fig. 5. This feature will be described in greater detail later in the application.

5 In the preferred embodiment, the porous core 135 comprises generally a plurality of stainless steel metal beads that has bonded thereto a powder consisting of phosphorous, chromium, iron, and nickel. The powder is referred to as a BNI-7 compound and in one embodiment consist of approximately 4% phosphorous, 17% chromium, 1% iron and 79% nickel. In another embodiment the brazing powder may
10 contain at least 1% phosphorous, at least 10% chromium, at least 0.5% iron and at least 60% nickel.

A brazing process is utilized. In other embodiments, the beads could be selected from a group consisting of chromium, ceramic, silica, titanium, and/or copper. Basically,
15 the method of manufacturing the porous core comprises the steps of providing the previously described container 46 with the soluble disc member already pressed fitted thereon. The container 46 is then filled with the unconsolidated beads. Next, the container with beads therein and the BNI-7 powder, which has been added to the container, is placed within a heating chamber, and the air in the heating chamber is
20 evacuated. Then, the heating chamber is filled under pressure with a gas. Next, the heating chamber is heated in order to consolidate the beads. In one embodiment, the chamber is heated to 2000 degrees fahrenheit in order to properly braze the beads together. The resulting core is very porous and highly permeable. Also, the core exhibits significant compressive strength which is an important factor since the sleeve

will undergo significant tensile and compressive forces during the deployment. The core is also adhered to the bore surface 128.

5 The sleeve 46 will be placed in the furnace on a flat plate with a sized knob protruding upward to hold sleeve 46 in place during the brazing process, to hold the beads within sleeve 46 without spillage, and to fix distance between the bead front and the bottom (ratchet) end of sleeve 46, where the dissolvable disc will be press fit at a later time.

10 The internal grooves 130 must be present in the second sleeve 46 in order to provide additional brazing surface area, and to greatly increase forces necessary to shear brazed beads to failure. The plane of failure is across composite beads/brazing material rather than pure brazing material and friction on interior wall of the second sleeve 46.

15

The beads should be placed inside sleeve 46 to a fixed height and volume so that the distance between the top edge of sleeve 46 and the beads allows the mechanical diverter ball to seat on the chamfered surface 132 as shown in Fig. 5. The beads and brazing material should be composed of corrosion resistant material because
20 of the corrosive nature of the down hole environment.

The beads should be sized to optimize sand control performance. In other words, the beads should be sized to prevent formation sand migration into the internal

diameter of casing 20, but also allow for the maximum porosity and permeability of the core 135 so that production of the reservoir fluids and gas is maximized.

As can be seen in Fig. 3, the housing 42, with the first sleeve 44 and second sleeve 46 are telescoped so that the device is in a retracted position. Thus, the thread means 49 of the housing 42 are threadedly engaged with thread means formed within an opening on the casing string 20. The make up of the housing 42 to the opening within the casing 20 forms a seal. The first sleeve 44 is positioned within the housing 42 such that the radially flat end 90 of the first sleeve 44 is aligned with the radially flat end 50 of the housing 42 and the radial surface 126 of the second sleeve 46.

In operation, the mechanical activation means 138, which in Fig. 3 is a wiper plug, is lowered down into the casing string 18 until the wiper plug 138 contacts the first end 70 of the first sleeve 44 which will cause both the first sleeve 44 and second sleeve 46 to move from the retracted position to an intermediate position such that the detent means 139A (snap ring member) for preventing backward movement of first sleeve 44 of the housing member engages the groove 82 located on the first sleeve 44 so that the first sleeve 44 is locked into this extended position. It should be noted, however, that the second sleeve 46 is still in its retracted position relative to the first sleeve 44. A typical wiper plug 138 is available from Weatherford International Inc. under the trade name WiperLok. The wiper plug 138 is pumped down using conventional techniques such as during cementing procedures.

Next, hydraulic pressure is then applied to the internal diameter of the casing string 18. The hydraulic pressure at the second sleeve 46 will then act on the barrier material that is coating the metal core as previously described, as well as acting on the surfaces 132 and 133 so that the second sleeve 46 extends outward to the formation face 25 as seen in Fig. 4. In this position, the ratchet grooves 120 will cooperate with the detent means 139B. Thus, as each successive ratchet groove 120 moves past the detent means 139B, movement in the opposite axial direction is precluded because of the ratchet type of design. The second sleeve will proceed outward until either the radial end 126 contacts the formation face 25 or until all ratchet pawls have been extended past the detent means 139B.

The entire sand control means, including the first 44 and second sleeve 46, may be extended by purely hydraulic means in the event that the mechanical means is not practical or undesirable. In this case, the operator would have to pump down the casing string a type of composition that would coat the metal core, or alternatively, a soluble/impermeable compound could be placed on the core at the surface. The type of composition used to form an impermeable barrier would be PERFFLOW, available from Baker Hughes Incorporated. Next, the operator would begin applying pressure to the internal diameter of the casing string. The pressure would first form a filter cake of the PERFFLOW on the core.

Next, the pressure would act against the shoulders 132 and 133 of the second sleeve 46, the chamfered surface 106 of the first sleeve 44 as well as the impermeable barrier formed on the core surface. The deployment of the first and second sleeve is

similar to the deployment earlier described in that the first sleeve is first to extend, and the first sleeve 44 is locked relative to the housing member 42 by the detent means 139A. Generally, the first sleeve 44 extends first because it has greater surface area to which the pressure can be applied. Next, the second sleeve 46 moves outward and as the individual pawls of the ratchet 120 move past the detent means 139B, retraction is no longer possible. Continued pressuring of the inner diameter of the casing 18 will cause the second sleeve 46 to either fully extend or contact the formation face 25, whichever occurs first.

As seen in Fig. 5, a spherical ball 142 is shown seated in the seat profile 132. If it is determined that some of the perforations (i.e. porous cores 135) require acidization because of poor flow therethrough, then it may be necessary to pump a plurality of diverting balls 142 which would seek and seat into those perforations which have a low pressure drop therethrough. Then, as acid is pumped down the casing 20, the acid is diverted to those perforations that have high pressure drops therethrough since the balls 142 have been sealed into those perforations that have low pressure drops. The balls would be selected with a circumference that matches the profile of the chamfered surface 132. Increasing the internal diameter pressure causes the ball to seal against the chamfered surface 132. Ball injector systems are available from SPM Inc. under the trade name SUR-DROP BALL INJECTOR. This technique can be utilized throughout the life of the reservoir when it is necessary to perform remedial acid and/or fracture stimulations.

Referring now to Fig. 6, the method of testing an exploratory well will now be

described. The method includes the steps of positioning in the exploratory well a casing string 200, the casing string 200 that intersects a series of target reservoir 204, 206, 208. A test work string 209 is also run into the well that will have a re-settable packer member 210 that is capable of multiple setting and un-setting up and down the casing string. The test work string 209 will also contain a valve member 211 that will be movable from an open position to a closed position within the string 209.

Next, the position of the bottom hole assembly 202 is correlated as the casing string is run into the wellbore so that said bottom hole assembly means 202 is adjacent the target reservoir 204. In the preferred embodiment, the open hole logs will have already had been taken, and therefore, the location of the test hydrocarbon zones will have already been known. Thus, casing string 200 will have positioned thereon the sand control means 212, 214, 216 for completing and producing the well without producing the formation sand in the proper location situated within the casing string 200.

The sand control means 212, 214, and 216 will be the previously described sand control means containing the metal core, as well as the soluble compound. It should be noted that while Figs. 6, 7, & 8 depict a pair of sand control means, a plurality of sand control means could have been utilized which would have been spaced about the circumference of the casing as well as spacing them axially along the casing with the length being determined by the length of the reservoir to be tested. The packer means 210 is then sealed against the inner diameter of the casing 200 thereby forming an upper annulus 218 and 220.

Next, the lower sand control means 212 can be activated to an extended position

so that the permeable means contacts the target reservoir. In the preferred embodiment, the means of activating the extendable sand control means is through the two step hydraulic method previously described. The soluble means will then be dissolved by pumping an acid solution down the inner diameter of the work string 209.

5 Because packer means 210 is set, the acid solution will be diverted through the inner diameter of the work string 209 and into the sand control means 212.

Thus, once the sand control means 212 is extended and the soluble compound dissolved, the hydrocarbon zone 204 may be tested by flowing the target reservoir 204
10 by opening up the valve 211. Multiple flow and pressure build-up test may be taken by opening and closing the valve 211.

Since the exploratory well contains a lower 204, an intermediate 206, and an upper target reservoir 208, the step of positioning in the casing string includes placing
15 the completion means in the casing string so that the completion means 212, 214, and 216 corresponds to depths of the lower, intermediate and upper target reservoir. The step of testing the hydrocarbon zones includes lowering a test string having thereon a retrievable isolation packer means for isolating the well bore; setting the isolation packer means at a position above the lower target reservoir but below the intermediate target
20 reservoir, and flowing the well from the lower target reservoir 204. Necessary flowing periods followed by shut-in periods as is well known in the art may be accomplished.

Referring now to Fig. 7, the method may further comprise the steps of shutting-in the well by surface means (not shown). Next, a through tubing bridge plug 222 is run

through the work string 209 and positioned above the reservoir 204 so that the lower zone is now isolated. Alternatively, a plurality of balls that fit and seal-off within the surface 132 may also be pumped down in order to isolate the lower sand control means 212 as seen in Fig. 5. The packer means 210 can be un-seated and then repositioned
5 uphole at the position indicated at 224. The sand control means 214 can be hydraulically extended as already described. The soluble means may be dissolved by pumping an acid slurry. Again, a flowing and pressure build-up test may be performed by manipulation of the valve means 211. If it is determined that some of the perforations require acidization because of poor flow, then it may be necessary to pump a plurality
10 of diverting balls which would seek and seat into those perforations which have a low pressure drop therethrough, thus allowing the acid to be diverted to those perforations that have high pressure drops therethrough.

Referring now to Fig. 8, the method may further comprise the steps of shutting-in
15 the well as previously described. The through tubing bridge plug 222 is repositioned up the casing string utilizing conventional wireline means. The packer means 224 can be un-seated and then repositioned uphole at the position indicated at 226. The sand control means 216 can be extended as already described. The soluble means may be dissolved by pumping an acid slurry. Again, a flowing and pressure build-up test may
20 be performed by manipulation of the valve means 211.

Changes and modifications in the specifically described embodiments can be carried out without departing from the scope of the invention which is intended to be limited only by the scope of the appended claims.

5

CLAIMS

1. An apparatus for completing a well to a target reservoir sand comprising:

-a casing string having a lower segment presenting an aperture through the string;

-sand control device positioned within said aperture, for controlling the production of the reservoir sand, said device comprising:

-a tubular member having filter media therein, said member movably mounted in the aperture for movement in a direction generally along its longitudinal axis between a retracted position primarily within the casing string and an extended position in engagement with the wellbore sidewall at the reservoir;

15

-said tubular member being selectively operable in a first mode blocking fluid flow through the tubular member and in a second mode enabling fluid flow from the reservoir into the casing string.

20

2. The apparatus of claim 1 wherein the media comprises a plurality of beads consolidated by a bonding agent to form a fluid permeable member.

3. The apparatus of claim 2 wherein said consolidated beads comprise a metal alloy and said bonding agent is a brazing powder.

25

4. The apparatus of claim 1 wherein said filter media comprises a dissolvable filler material in the pores of the filter which blocks fluid flow when present in the filter.

- 5 5. The apparatus of claim 1 wherein said device comprises:
- an outer tubular member surrounding the first tubular member in a telescoping arrangement.
6. The apparatus of claim 1, further comprising at least one detent for preventing
10 backward motion of said tubular member, which is engageable with any one of a plurality of recess on the tubular member.
7. The apparatus of claim 6 wherein casing string contains a plurality of apertures disposed thereon and a plurality of said sand control devices disposed within
15 said plurality of apertures.
8. A method of completing a well comprising:
- positioning a casing into a well bore, said casing having a lower segment with an aperture therein for holding a sand control device for completing a target
20 reservoir, said sand control device comprising:
 - filter media for allowing the flow of fluid and gas from the target reservoir;
 - a tubular member moveably mounted in the aperture and holding said filter media;
 - 25 -the tubular member being operable between a first mode of operation blocking fluid flow therethrough and a second mod allowing fluid flow;
 - correlating the position of said sand control device with the target reservoir so that the completion means is adjacent the target reservoir;

- 5 - extending said tubular member from the casing housing from a retracted position to an extended position; and
- changing the mode of operation of the sand control device to enable flow of reservoir fluid into the casing string.
- 10 9. The method of claim 8 wherein said filter media contains a soluble filler material in the filter media for blocking flow of drilling fluids and cuttings, and the method further comprises the steps of:
- treating said permeable means so as to remove said soluble compound;
- and,
- 15 -placing the well on production.
10. The method of claim 8 wherein said tubular member contains a profile for receiving a movable valve member, and the method further comprises:
- pumping a movable valve member down said casing;
- 20 -seating one of said members in said profile so that said sand control device is isolated.

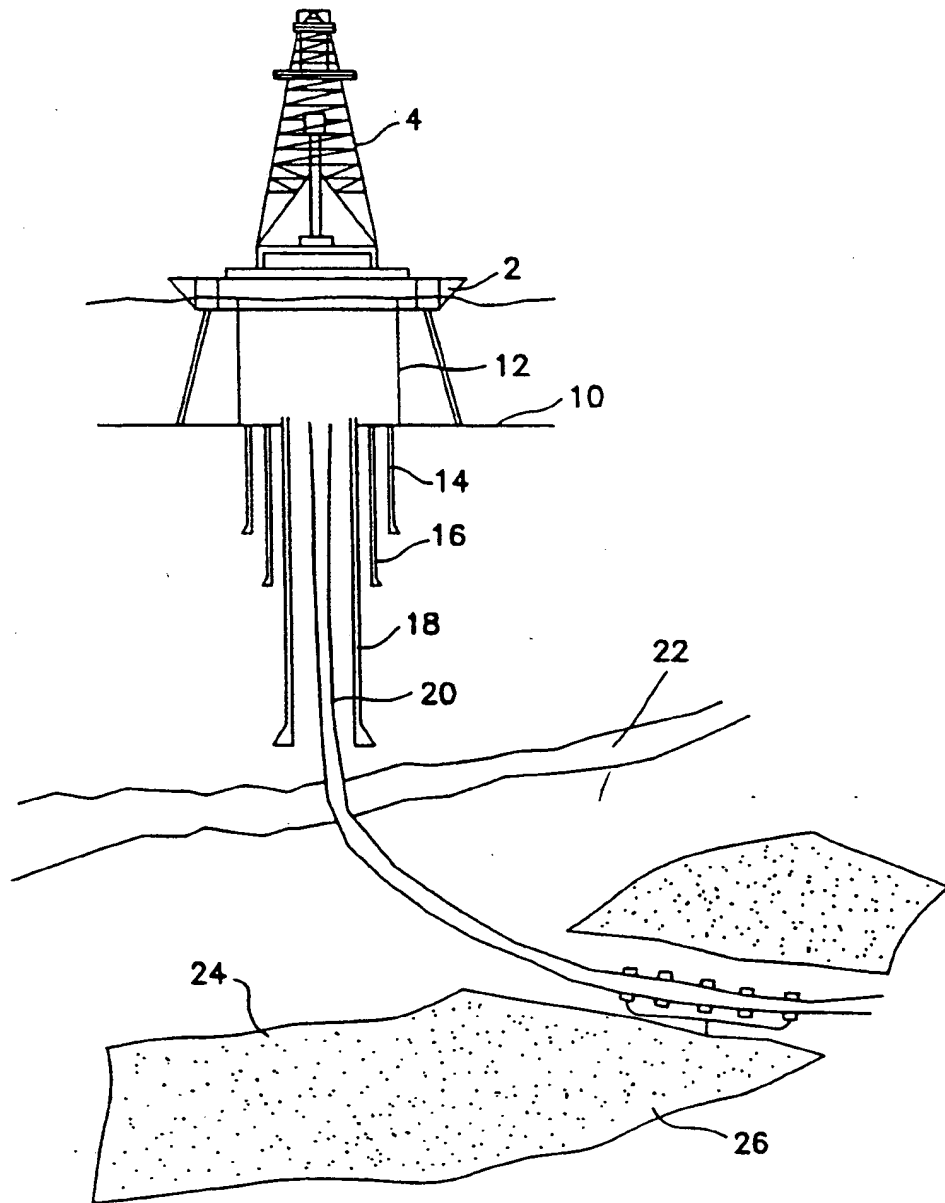

FIG. 1

SUBSTITUTE SHEET (RULE 26)

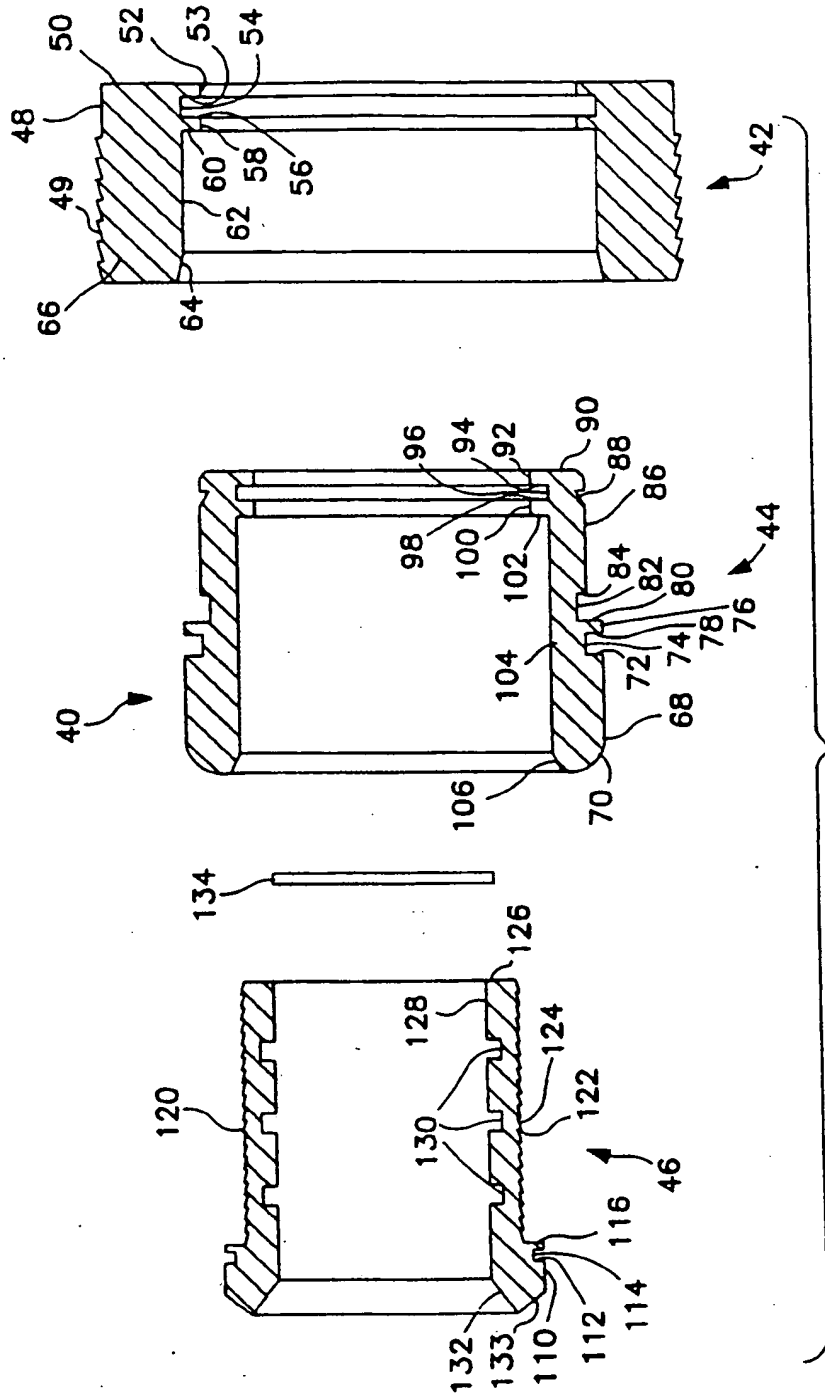

FIG. 2

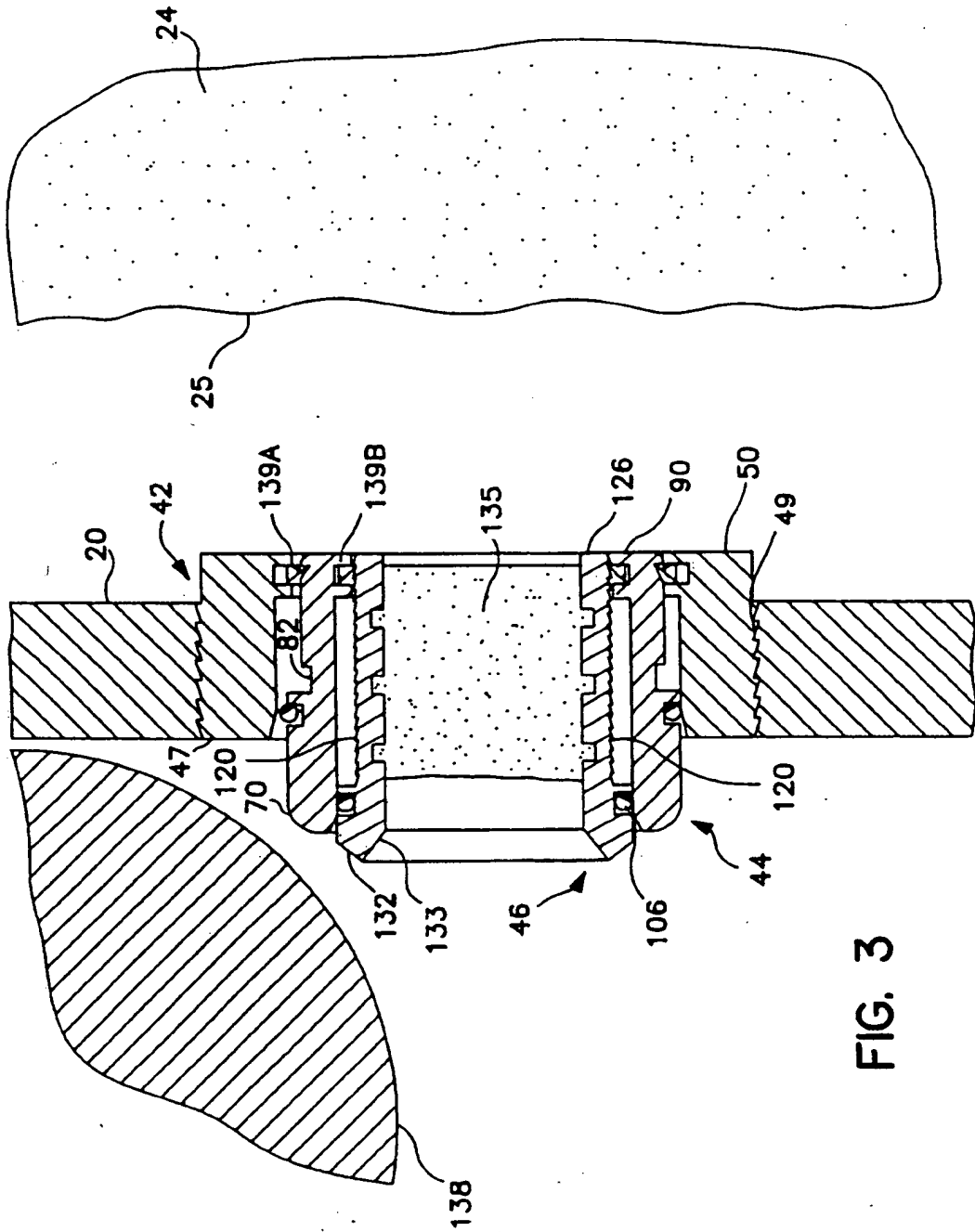

FIG. 3

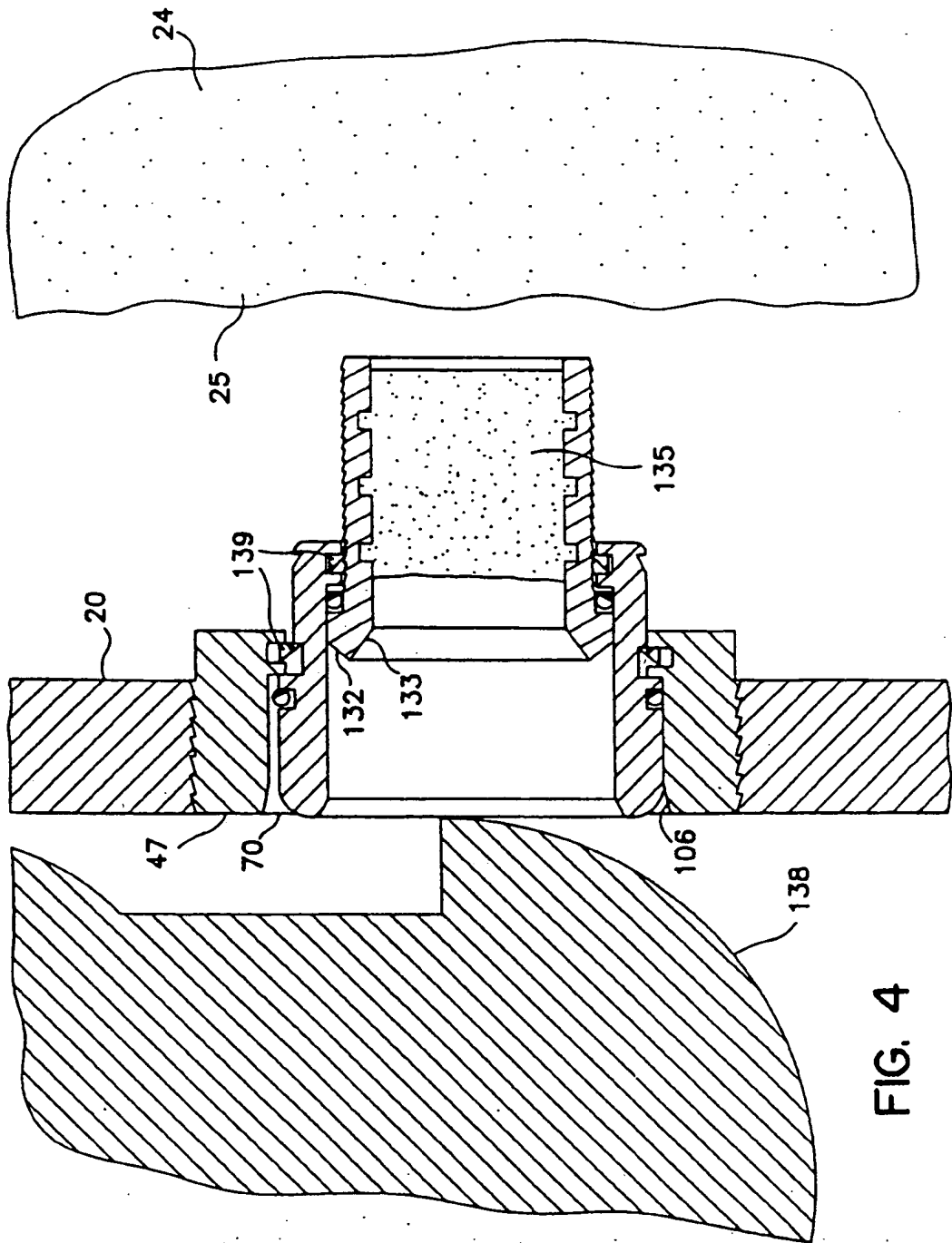

FIG. 4

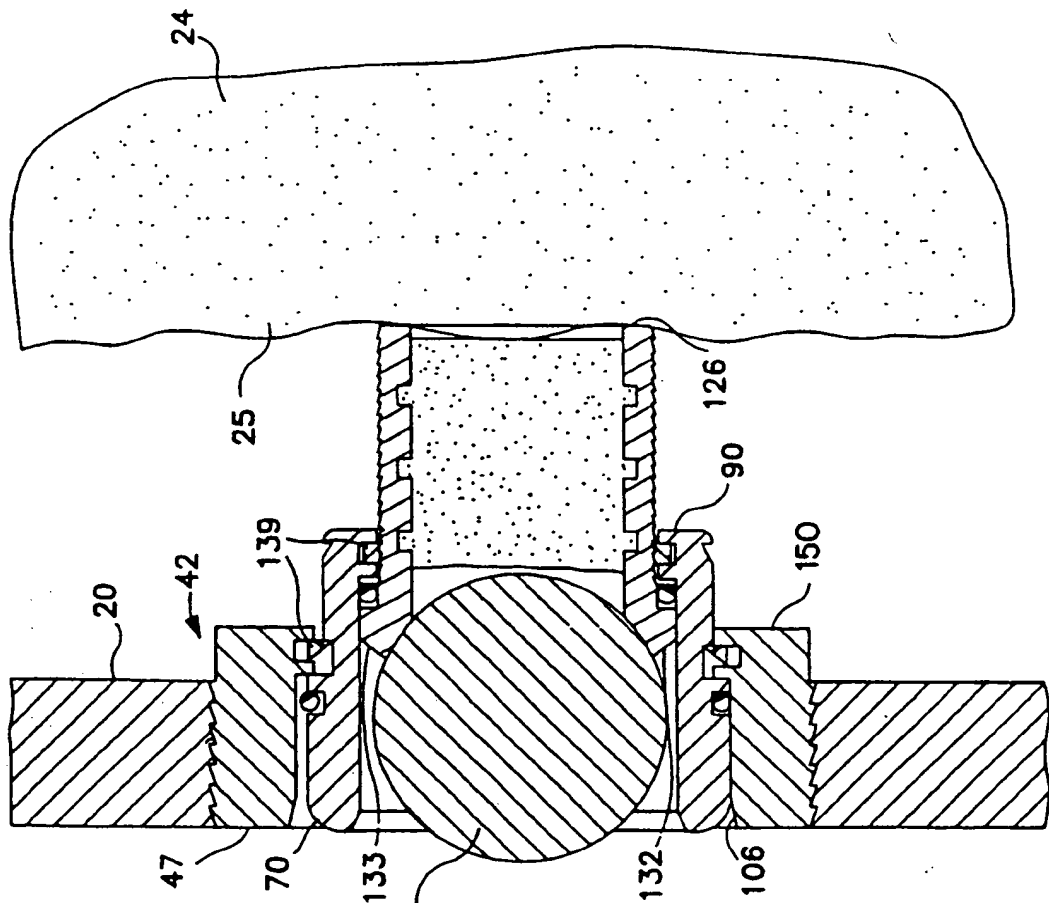

FIG. 5

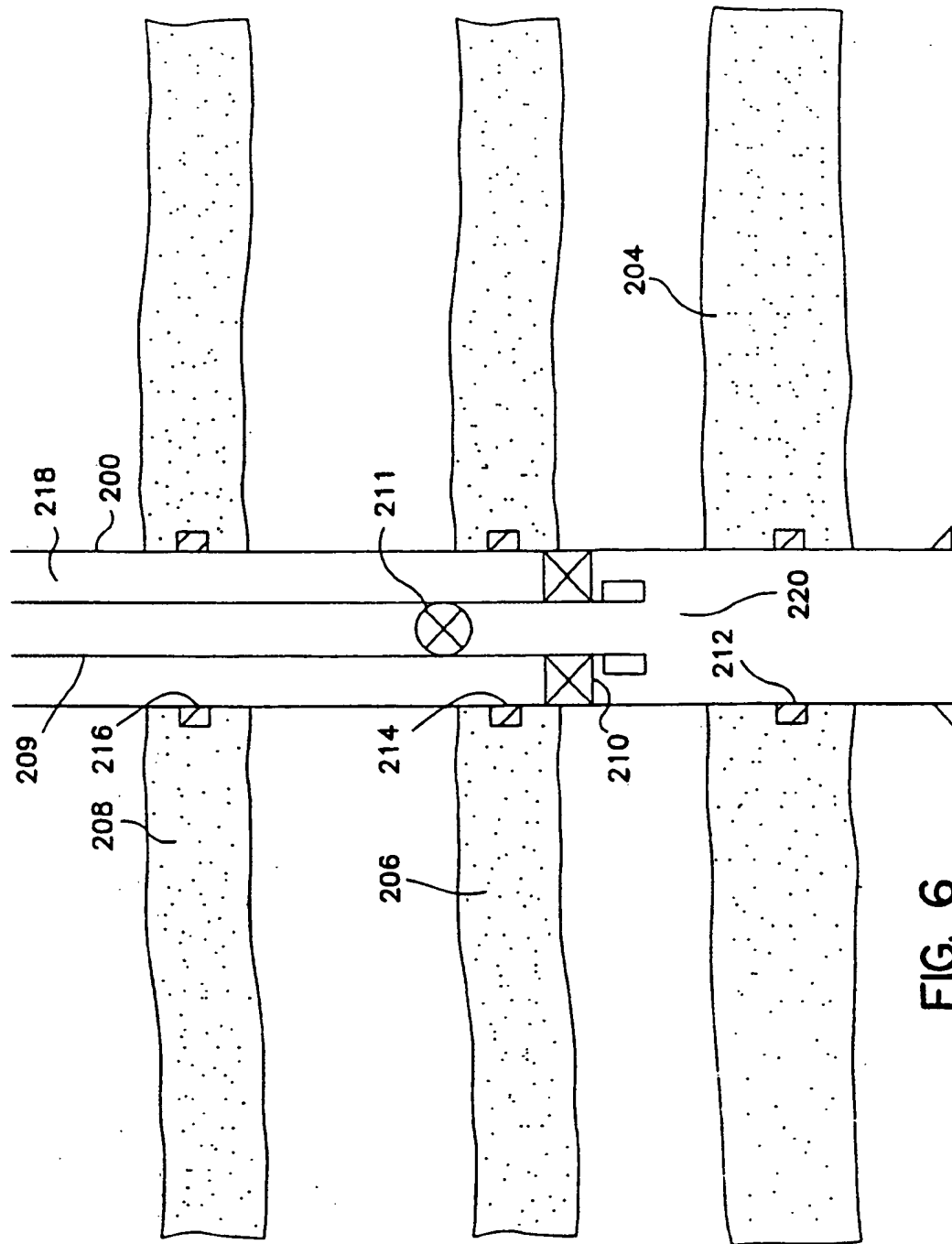

FIG. 6

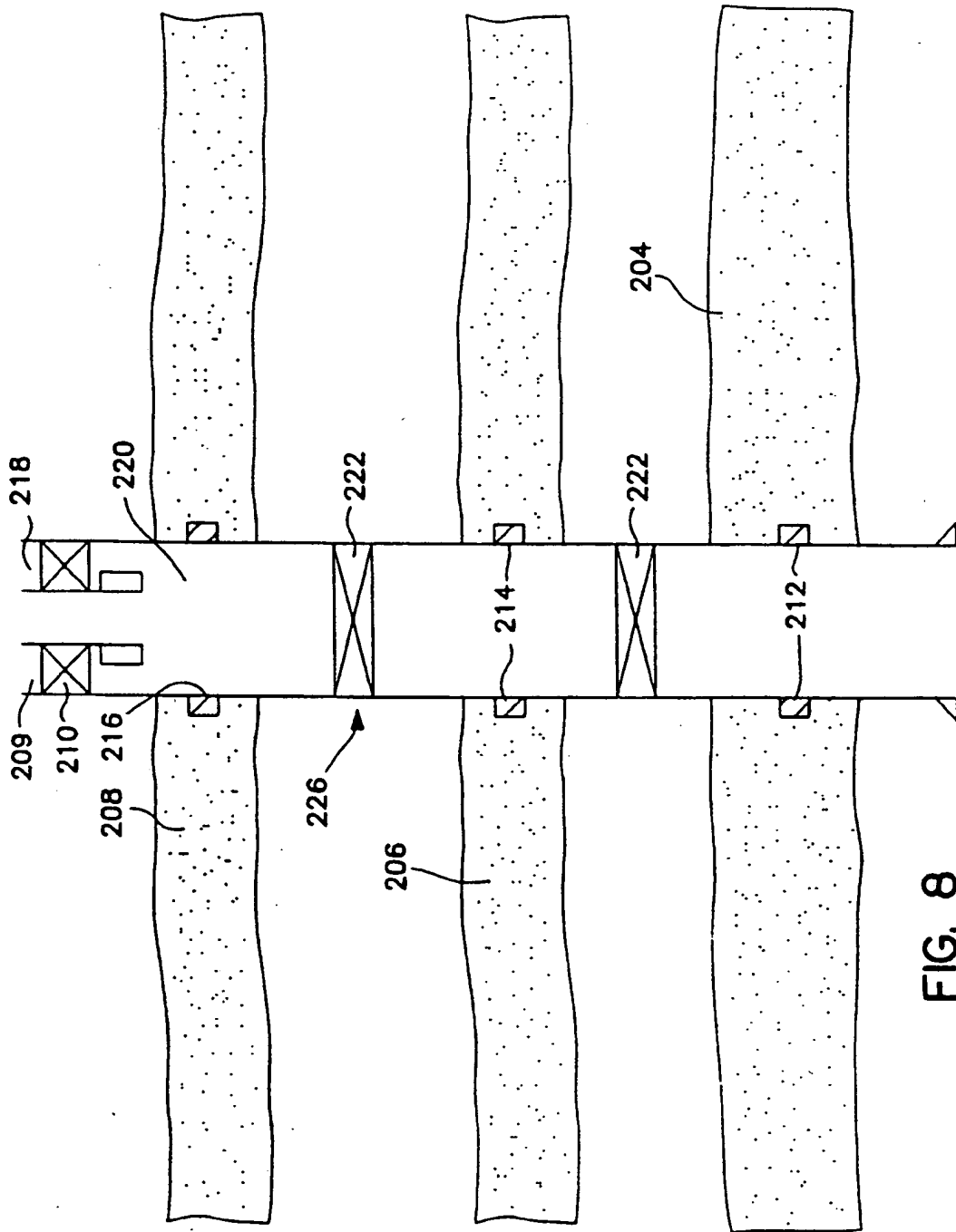

FIG. 8

INTERNATIONAL SEARCH REPORT

Internat. Application No.
PCT/US 96/02050

A. CLASSIFICATION OF SUBJECT MATTER
IPC 6 E21B43/11 E21B43/08

According to International Patent Classification (IPC) or to both national classification and IPC

B. FIELDS SEARCHED

Minimum documentation searched (classification system followed by classification symbols)
IPC 6 E21B

Documentation searched other than minimum documentation to the extent that such documents are included in the fields searched

Electronic data base consulted during the international search (name of data base and, where practical, search terms used)

C. DOCUMENTS CONSIDERED TO BE RELEVANT

Category *	Citation of document, with indication, where appropriate, of the relevant passages	Relevant to claim No.
X	US,A,2 708 000 (ZANDMER) 10 May 1955 see column 3, line 58 - column 4, line 11 ---	1,4,5, 7-9
X	US,A,3 425 491 (ZANDMER) 4 February 1969 see column 5, line 34 - line 50 see column 3, line 7 - line 30 see abstract ---	1,4,5, 7-9
X	US,A,3 326 291 (ZANDMER) 20 June 1967 see column 3, line 72 - column 4, line 11 see column 3, line 13 - line 17 ---	1,5-8
A	see column 3, line 60 - line 67 ---	2,4,9
	-/--	

Further documents are listed in the continuation of box C.

Patent family members are listed in annex.

* Special categories of cited documents:

- *A* document defining the general state of the art which is not considered to be of particular relevance
- *E* earlier document but published on or after the international filing date
- *L* document which may throw doubts on priority claim(s) or which is cited to establish the publication date of another citation or other special reason (as specified)
- *O* document referring to an oral disclosure, use, exhibition or other means
- *P* document published prior to the international filing date but later than the priority date claimed

- *T* later document published after the international filing date or priority date and not in conflict with the application but cited to understand the principle or theory underlying the invention
- *X* document of particular relevance; the claimed invention cannot be considered novel or cannot be considered to involve an inventive step when the document is taken alone
- *Y* document of particular relevance; the claimed invention cannot be considered to involve an inventive step when the document is combined with one or more other such documents, such combination being obvious to a person skilled in the art.
- *A* document member of the same patent family

Date of the actual completion of the international search

30 May 1996

Date of mailing of the international search report

31 07. 96

Name and mailing address of the ISA
European Patent Office, P.B. 5818-Patentlaan 2
NL - 2280 HV Rijswijk
Tel. (+ 31-70) 340-2040, Tx. 31 651 epo nl,
Fac. (+ 31-70) 340-3016

Authorized officer

SOGNO H.G.

INTERNATIONAL SEARCH REPORT

International application No.

PCT/US 96/02050

Box I Observations where certain claims were found unsearchable (Continuation of item 1 of first sheet)

This international search report has not been established in respect of certain claims under Article 17(2)(a) for the following reasons:

1. Claims Nos.:
because they relate to subject matter not required to be searched by this Authority, namely:

2. Claims Nos.:
because they relate to parts of the international application that do not comply with the prescribed requirements to such an extent that no meaningful international search can be carried out, specifically:

3. Claims Nos.:
because they are dependent claims and are not drafted in accordance with the second and third sentences of Rule 6.4(a).

Box II Observations where unity of invention is lacking (Continuation of item 2 of first sheet)

This International Searching Authority found multiple inventions in this international application, as follows:

2-7, 9, 10

1. As all required additional search fees were timely paid by the applicant, this international search report covers all searchable claims.

2. As all searchable claims could be searched without effort justifying an additional fee, this Authority did not invite payment of any additional fee.

3. As only some of the required additional search fees were timely paid by the applicant, this international search report covers only those claims for which fees were paid, specifically claims Nos.:

4. No required additional search fees were timely paid by the applicant. Consequently, this international search report is restricted to the invention first mentioned in the claims; it is covered by claims Nos.:

2-7, 9

Remark on Protest

- The additional search fees were accompanied by the applicant's protest.
- No protest accompanied the payment of additional search fees.

INTERNATIONAL SEARCH REPORT

Information on patent family members

Internal	Application No
PCT/US 96/02050	

Patent document cited in search report	Publication date	Patent family member(s)	Publication date
US-A-2708000	10-05-55	NONE	
US-A-3425491	04-02-69	NONE	
US-A-3326291		NONE	
US-A-3347317	17-10-67	NONE	
US-A-3390724	02-07-68	NONE	
US-A-5425424	20-06-95	CA-A- 2142917 DE-A- 19506794 DK-A- 19795 GB-A- 2286846 NO-A- 950742	29-08-95 31-08-95 29-08-95 30-08-95 29-08-95
US-A-3057405	09-10-62	NONE	
US-A-5339895	23-08-94	CA-A- 2119520 EP-A- 0617194 JP-A- 7048983 NO-A- 941011	23-09-94 28-09-94 21-02-95 23-09-94
US-A-5088554	18-02-92	CA-A- 2092308 CN-A, B 1060886 DE-D- 69117966 EP-A- 0553209 JP-T- 6501069 US-A- 5293935 WO-A- 9207167 US-A- 5190102	23-04-92 06-05-92 18-04-96 04-08-93 27-01-94 15-03-94 30-04-92 02-03-93